



.....

***HAWK 2 Family:***

.....

***ST12400N/ND/NC***

.....

***ST11900N/ND/NC***

.....

.....

***Installation Guide***

.....

## Contents

<b>Introduction</b> .....	<b>1</b>
<b>Electromagnetic interference</b> .....	<b>1</b>
<b>Before you begin</b> .....	<b>2</b>
<b>Installation overview</b> .....	<b>7</b>
<b>Product repair information</b> .....	<b>9</b>
Shipping .....	10
Product repair and return information .....	10
<b>Technical support services</b> .....	<b>11</b>
<b>Drive specifications</b> .....	<b>14</b>
<b>Initial set-up information</b> .....	<b>17</b>
<b>Drive configuration</b> .....	<b>23</b>
<b>Drive installation</b> .....	<b>33</b>
<b>Drive Setup</b> .....	<b>37</b>

© 1994 Seagate Technology, Inc. All rights reserved  
Publication Number: 77767451, Rev. C.  
March 1994

Seagate®, Seagate Technology® and the Seagate logo are registered trademarks of Seagate Technology, Inc. Hawk™, SeaFAX™, SeaFONE™, SeaTDD™, SeaBOARD™ are trademarks of Seagate Technology, Inc. Other product names are registered trademarks or trademarks of their own.

Seagate reserves the right to change, without notice, product offerings or specifications. No part of this publication may be reproduced in any form without written permission of Seagate Technology, Inc.

---

## **Introduction**

Before attempting any installation, please read through all applicable sections of this document, including all warnings and cautions.

**Warning.** This equipment generates, uses, and can radiate radio frequency energy and if not installed in accordance with these instructions, may cause interference to radio communications.

## **Electromagnetic interference (EMI) considerations**

The drive(s) described herein, as delivered, are designed for system integration and installation into a suitable enclosure prior to use. As such, the drive(s) described herein are supplied as a sub-assembly and are not subject to Subpart J of Part 15 of the FCC Rules and Regulations nor the Radio Interference Regulations of the Canadian Department of Communications. However, the unit has been tested using proper shielding and grounding and found to be compliant with the Class A limits of the FCC Rules and the Regulations of the Canadian Department of Communications.

The physical design characteristics of the drive(s) described herein, serve to minimize EMI radiation when installed in an enclosure that provides reasonable shielding. As such, the drive(s) are capable of meeting the Class B limits of the FCC Rules and the Regulations of the Canadian Department of Communications.

**Note.** It is the end users' responsibility to assure that the drive(s) described herein meet the appropriate EMI requirements of their system. Shielded I/O cables may be required if the enclosure does not provide adequate shielding. If I/O cables are external to the enclosure, shielded cables should be used, with the shields grounded to the enclosure and to the host controller.

### ***Before you begin***

**Verify that the system is switched off and disconnected from main power before any installation is attempted.**

**Protect yourself, the drive, and your valuable programs and data by reading the following cautions and warnings.**

- 
- Do not unpack drive from its static shielded bag until you are ready to install it in the system.
  - Always handle the drive by the frame or casting.
  - Do not touch printed circuit board (PCB) or the I/O connector pins.
  - Never apply pressure to the PCB or to the drive top cover.
  - Do not tamper with sealed top cover. Doing so voids your warranty. The drive contains no user serviceable components. See Product Repair section for more information.
  - Visually inspect the shipping container for any obvious damage.
  - Inspect drive for possible shipping damage. All claims of this type should be filed promptly with the transporter involved. Save original packing materials to be used when reshipping.
  - Verify all parts listed on shipping bill are received with the equipment. Discrepancies or damage should be reported to the shipping company.
  - When transporting or shipping a drive or system, please ensure that they are correctly packed in original Seagate approved (or equivalent) container and shipped via an air-ride carrier experienced in handling computer equipment.

**Caution.** The circuit assemblies and components contained in this equipment can be degraded or destroyed by Electrostatic Overstress (EOS) or by Electrostatic Discharge (ESD).

Static electrical charges can accumulate quickly on personnel, clothing and synthetic materials. The electrostatic fields due to these charges when brought in close proximity to susceptible circuit assemblies and components, can result in degraded reliability or immediate failure of the affected component or assembly.

To insure optimum reliable equipment operation, it is required that technical support personnel discharge themselves by wearing a grounding strap around the wrist and be connected to a grounding terminal while working in the vicinity of, and while handling EOS/ESD susceptible assemblies/parts. If unavailable, ground yourself frequently by touching the metal chassis of the system before handling any components (this helps only if the system is connected to a ground). *Avoid static-inducing carpeted areas.* This procedure is especially important when handling printed circuit boards (PCBs).

---

**Safety instructions**

1. The disc drive(s) are to be installed in a customer supplied enclosure where the surrounding air does not exceed 50°C.
2. Four (4) 6-32 UNC-2A screws are required for installation. Maximum screw length into side of drive is 0.15 inches (3.81 mm). Maximum screw length into bottom is 0.20 in. (5.08 mm). Maximum screw tightening torque is 8.0 in-lb (0.90 NM) with minimum thread engagement of 0.12 in. (3.0 mm).
3. The power requirements are shown in Section 1.0 Product Information.
4. The power supply must satisfy the safety requirements for SELV (Safety Extra Low Voltage) circuits.
5. Service is to be provided by trained Seagate service personnel.
6. The incorporation of the disc drives listed in this guide into a customer enclosure must meet the appropriate safety requirements of the country in which it is used (e.g. UL 1950, CAN/CSA-C22.2 No. 950-M89, DIN VDE 0805/05.90 and EN60950: 1988 (IEC 950)).

**Sicherheitsanleitung**

1. Das Gerät ist ein Einbaugerät, vorgesehen für eine maximale Umgebungstemperatur von 50°C.
2. Zur Befestigung der Drive werden 4 Schrauben benötigt (6-32 UNC-2A). Die maximale Länge der Schrauben in der unteren Seite des Chassis darf nicht mehr als 0.20 in (5.08 mm) betragen, die in der oberen 0.15 in (3.81 mm). Maximale Schraubenanziehung Von 8.0 in-lb (0.90 NM) mit minimalem Gewindeansperuch 0.12 in. (3.0 mm).
3. Die Versorgungsspannungen werden im Kapitel 1.0 (Produkt Information) gezeigt.
4. Die Versorgungsspannung muss SELV entsprechen.
5. Alle Arbeiten dürfen nur von ausgebildetem Seagate Service-Personal durchgeführt werden.
6. Der Einbau des Drives muss den Anforderungen gemäss DIN VDE 0805/05.90 oder EN60950: 1988 (IEC 950).



---

## Installation Overview

Installation of the drive can be divided into distinct phases as outlined below. Some of these may not be applicable to your particular installation requirements. Refer to the individual drive installation sections for specific information on your drive model.

- **Drive configuration:** The user must select which of the drive features are appropriate to enable for installation in their system. This is done by way of the user configuration jumpers found on the drive PCB.
- **Mechanical installation:** After setting up the drive configuration the drive must be mechanically installed into the host system and the power and I/O cables attached. Previously mentioned precautions should be observed
- **SCSI drives should not be defined in the CMOS:** The SCSI Host adapter has its own BIOS to handle the Input/output procedures. The CMOS setting for SCSI drive is either drive type zero, or the "no drive installed" option.

- **Low-level formatting:** After the drive has been properly configured for the system, it does not need to be low-level formatted, as this has been done by the factory and does not require this step during installation. (The low-level format writes the sector boundaries and track information to the drive). Defect management information is read from the drive by the host system when required in the installation procedure. If an installed drive is low-level formatted, all user data stored on the drive will be lost.

**Note. Seagate Technology assumes no liability for lost user data.**

- **Partitioning and high level formatting:** A drive can be sub-divided into "partitions" which behave as individual drives within the system. See your system documentation. Present day drive installation programs have menus that lead you through these installation procedures.

---

## Product repair information

### Service requirements

The special facilities required for the manufacture of these drives generally prohibit repair in the field. If problems occur during installation, please contact your supplier for assistance. Do not attempt to disassemble or repair. Drives should be sent to the repair depot through the purchase source, if possible. Please observe the following cautions.

#### **Caution.**

- Handle drive with care. Do not drop or bump hard.
- **Never** remove the cover of these disc drives. Servicing items in the sealed HDA (heads, media, actuator, etc.) require special facilities. The drive contains no user purchasable parts or PCBs.
- Opening the sealed HDA voids the drive warranty.
- Applying a soldering device to the components on the PCB voids the drive warranty.

- Place drive on a flat, static dissipative surface and handle with extreme care. Always follow all EOS/ESD precautions to avoid damage to the electrical assemblies.

**Shipping:** When transporting or shipping a drive, a Seagate approved container must be used. Keep your original box. They are easily identified by the Seagate Approved Package label. Shipping a drive in a non-approved container voids the drive warranty.

Seagate repair centers may refuse receipt of components improperly packaged or obviously damaged in transit. Contact your Authorized Seagate Distributor to purchase additional boxes. Seagate recommends shipping by an air-ride carrier experienced in handling computer equipment.

### **Product repair and return information**

Seagate customer service centers are the only facilities authorized to service Seagate drives. Seagate does not sanction any third-party repair facilities. Any unauthorized repair or tampering with the factory-seal voids the warranty.

#### **Warranty:**

Contact your Seagate Authorized Distributor, Dealer or other purchase source for warranty information.

If the drive is no longer under warranty contact purchase source for repair information or refer to numbers listed in the following paragraph .

### **Technical support services**

Please contact your dealer for technical support and installation troubleshooting. Product Technical Support is available for all Seagate products by calling the SeaFAX, SeaFONE or SeaBOARD services. These are toll calls.

#### **SeaFAX: 408/438-2620**

You can use a Touch-Tone telephone to access Seagate's automated FAX delivery system and select technical support information by return FAX. This service is available 24 hours a day, 7 days a week.

#### **SeaFONE: 408/438-8222**

The enhanced phone system provides recorded technical information on selected Seagate products while you are on hold. Technical support specialists are available to answer questions from 8:00 AM to 5:00PM PST, Monday through Friday. Recordings are accessible 24 hours a day, 7 days a week.

**SeaTDD: 408/438-5382**

TDD is a Telecommunication Device for the Deaf where two people can communicate using a keyboard that is connected to the phone line. A TDD device is required to access this service. This service is available from 8:00 AM to 5:00 PM PST, Monday through Friday.

**SeaBOARD:**

The Seagate Technical Support Bulletin Board System (BBS) is available 24 hours a day, 7 days a week. A modem is required to access this service. The communications software must be set for eight data bits, no parity and one stop bit (8N1).

With this service you can access:

- Specifications and jumper configurations for all Seagate products.
- Reprints of Seagate documentation.
- A directory of information and helpful utilities that you can download to your own computer.

<b>BBS Location</b>	<b>Modem Number</b>	<b>Maximum Baud Rate</b>
United States	408-438-8771	9600
England	44-62-847-8011	9600
Germany	49-89-140-9331	2400
Singapore	65-227-2217	9600
Australia	61-2-756-2359	9600

**Note: These are toll calls**

## Drive specifications

<b>Product Information</b>	<b>Hawk 2 Family</b>	
	<b>ST12400N/NC</b>	<b>ST12400ND</b>
Interface [7]	SCSI-2 Fast	SCSI-2 Fast
Cache Type	Multi-segmented, 256 Kb	
Capacity MB		
Unformatted	2537	2537
Formatted [1]	2148	2148
Cylinders	2621	2621
Heads	19	19
Sectors/track (Avg.)	84	84
Recording method	RLL (1,7)	RLL (1,7)
Rev/min	5411	5411
<b>Seek time (ms typ.)[2]</b>		
Average		
Read	9.0	9.0
Write	10.5	10.5
<b>Operating environment</b>		
Ambient temp. [4]	----- 5°C to 50°C-----	
HDA max temp. [3]	-----60°C-----	
<b>Power requirements (Versorgungsspannungen)</b>		
+12 V +/-5% (Max [6])	1.0 A	1.0 A
(Max Start) [5]	2.0 A	2.0 A
+5 V +/-5% (Max) [6]	0.8 A	1.0 A
(Max Start)	0.8 A	0.9 A
Power Idle (Typ)	9.0 W	10 W
Oper. (Typ)	11.0 W	12 W



Product Information	Hawk 2 Family	
	ST11900N/NC	ST11900ND
Interface [7]	SCSI-2 Fast	SCSI-2 Fast
Cache Type	Multi-segmented, 256 Kb	
Capacity MB		
Unformatted	2003	2003
Formatted [8]	1700	1700
Cylinders	2621	2621
Heads	15	15
Sectors/track (Avg.)	84	84
Recording method	RLL (1,7)	RLL (1,7)
Rev/min	5411	5411
<b>Seek time (ms typ.)[2]</b>		
Average		
Read	9	9
Write	10.5	10.5
<b>Operating environment</b>		
Ambient temp. [4]	-----5°C to 50°C-----	
HDA max temp. [3]	-----60°C-----	
<b>Power requirements (Versorgungsspannungen)</b>		
+12 V +/-5% (Max) [6]	1.0 A	1.0 A
(Max Start) [5]	2.0 A	2.0 A
+5 V +/-5% (Max) [6]	0.8 A	1.0 A
(Max Start)	0.8 A	0.9 A
Power Idle (Typ)	9.0 W	10 W
Oper. (Typ)	11.0 W	12 W

**Notes.**

- [1] Standard Hawk 2 units are factory formatted with 512 data bytes per sector with twelve spare sectors per cylinder and 2 cylinders at inner tracks reserved for spares in addition to capacity listed.
- [2] Does not Include on-board controller overhead.
- [3] Maximum measured at any location on top cover.
- [4] For best reliability keep below 35°C (95°F).
- [5] A droop of up to -10% is permissible for a maximum of 10 seconds at power up. (abfall van -10% is erlaubt für 10 Sekunden max).
- [6] Measured with an average reading DC ammeter. Instantaneous +12 V current peaks will exceed these values.
- [7] Can be commanded to operate according to SCSI-1 protocol.
- [8] Standard ST11900 units are factory formatted with 512 data bytes per sector with six spare sectors per cylinder and 2 cylinders at inner tracks reserved for spares in addition to capacity listed.

---

## Initial setup information

For the initial setup connect the cables, set the SCSI bus address and remove, install, or leave as is the SCSI I/O line terminator resistor packs. These procedures are described in paragraphs following. Before continuing, note whether drive model number letter suffix contains N, ND or NC.

### SCSI interface cable connection

Hawk 2 family model drives are SCSI interface drives. System connection is via a 50 pin, SCSI connector, except for "NC" models which have an 80 pin combined SCSI I/O and power connector, Pin 1 is noted in Figure 1 for the 50 pin connector. Some cables have a contrasting color stripe on one edge to indicate pin 1. Because of the non-symmetrical shape of the 80 pin connector there is only one way that it can mate with the input connector. Strain relief is recommended for the cable. *Do not block system cooling air flow in routing of cables.*

**SCSI address selection**

On "N/ND" drives, make sure that the SCSI bus address jumper(s) are properly set for the bus address assigned to the drive. See figures at beginning of Section 3 showing the bus address select header and the jumper configurations that select addresses 0 through 7. Typically the primary boot device is set to ID 0, and the subsequent SCSI drives are jumpered in ascending order. Bus addresses 0 through 6 should be used (the host adapter usually uses address 7). If the drive LED shows no on/off activity when the host is trying to communicate with it, an incorrect bus address selection at the drive should be suspected.

On "NC" model drives the SCSI ID can be, and presumably will be set over the 80 pin interface by the host computer. Unless directed to do so by the host system documentation, no jumpers should be installed for address selection. On "NC" models, the host has also complete control over motor start functions, so no motor start or delayed motor start jumpers should be installed.

**Resistor terminator packs**

If you are installing a single drive, the Terminator Enable (TE) jumper must be installed. See option select jumper header in Figure 2a . If you are installing multiple hard disc drives, remove the Terminator Enable (TE) jumper from all the drives but the one connected to the end of the SCSI I/O cable.

Model numbers that end in "ND" have differential I/O circuits and these drives have no provisions for terminators that plug into the drive PCB. The user, systems integrator or system manufacturer must provide some external means of I/O line termination.

**Read/write head auto-park**

Seagate disc drives described herein park the heads automatically at power off. This feature requires no operator intervention.

**Optional parity bit enable**

Some systems require parity bit checking. Consult the system documentation for the specific requirements. See figures in Section 3 for location of Parity Bit Enable jumper. Jumper-on enables parity reporting by the SCSI bus.

**DC power connection**

Drive model numbers terminating with "N" or "ND" receive DC power through a 4 pin connector mounted on the PCB next to the SCSI I/O connector. See Figure 1.

Drive models terminating in "NC" receive DC power through the 80 pin I/O connector from the host computer. No separate DC power connection is available on the drive.

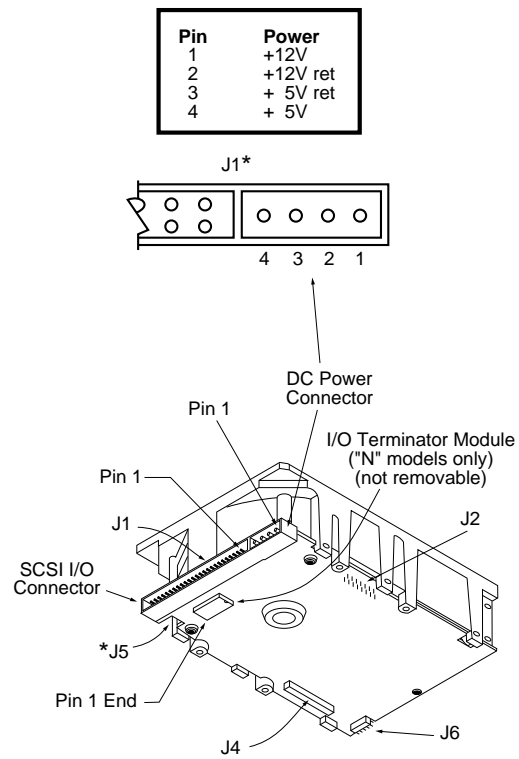

\* "NC" model drives have a single, 80 pin I/O connector that also provides DC power. It does not have J5.

**Figure 1a. "N" and "ND" model drives physical interface (50 pin SCSI I/O connector)**

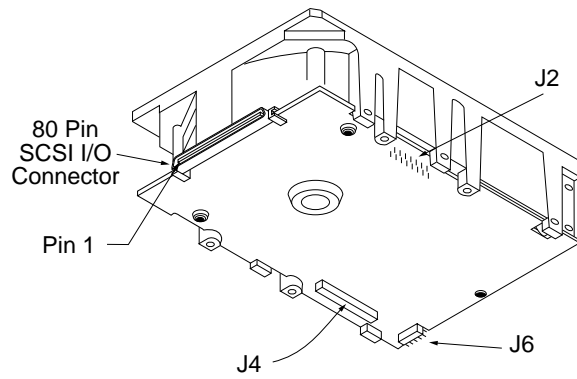

**Figure 1b. "NC" model drive physical interface (80 pin I/O and DC power connector)**



## **Drive configuration**

Each disc drive has option select header connectors on the sides and front where jumper plugs are installed to select the way that the drive is to be configured or to select its ID on the I/O bus.

### **SCSI I/O drives**

On SCSI I/O model "N/ND" drives either J6 (on the front of the drive) or J5 (on the side behind the SCSI I/O connector) may be used to set the drive ID. To avoid possible incorrect ID setting, do not use both J5 and J6 for ID selection. The following figures show where these headers are located on the different drives covered by this manual. There are notes following where explanations are given about the purpose of each jumper and specify the standard factory (called "default") settings of these jumpers (i.e., settings used for most common single drive application). Changes to these settings should be made only if it is known that the system requires a different configuration.

SCSI model "NC" drives do not have J5 for ID selection. The ID signals come in the 80 pin I/O connector, so drive ID selection can be made over the interface from the host. J6 can be used but probably is not to be used.

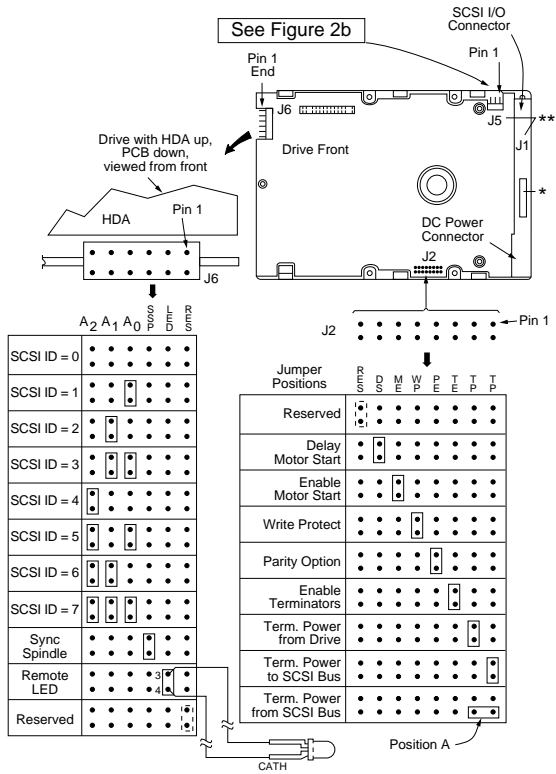

- \* PCB part number label here
- \*\* See Note [2] following Figure 2c.

**Figure 2a. Drive configuration for Hawk 2 family N/ND model**

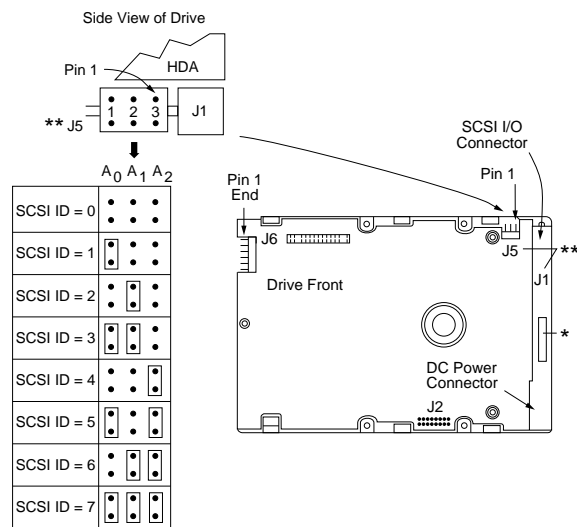

- \* PCB part number label here
- \*\* See Note [2] following Figure 2c.

**Figure 2b. Drive configuration for Hawk 2 family N/ND model**

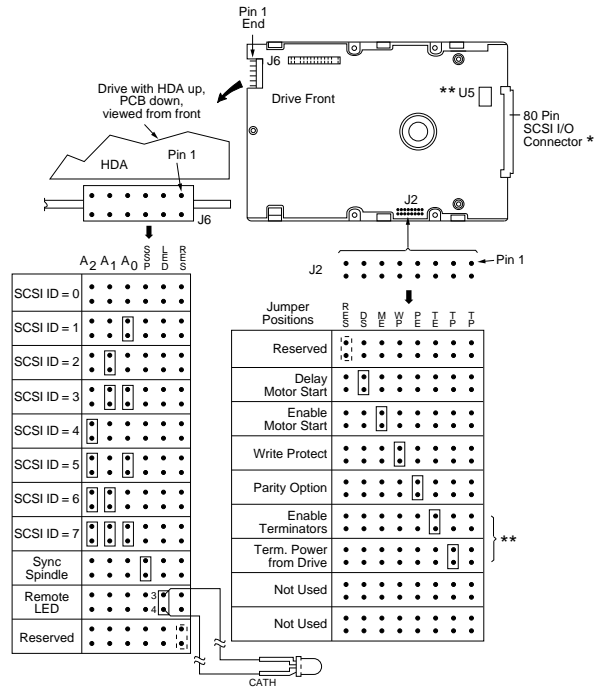

- \* See Note [2] following this figure.
- \*\* These two functions apply only on "NC" drives that have terminator module U5 installed (factory installed only).

**Figure 2c. Drive configuration for Hawk 2 family NC model**

**Notes for Figure 2a, 2b and 2c:**

- [1] Notes explaining the functions of the various jumpers on jumper header connectors J2, J5 and J6 are given below in left to right order of jumper position. The term "default" means as standard OEM units are configured when shipped from factory. "Off" means no jumper is installed; "On" means a jumper is installed. Off or On underlined is factory default condition.
- [2] The PCB on "NC" models does not have connector J5, and has a single 80 pin combined SCSI I/O and DC power connector instead of the normal 50 pin SCSI I/O and 4 pin DC power connectors. Included among the 80 pins are the SCSI ID, Motor Start and Delayed Motor Start select functions, and the synchronous spindle master sync signal and the remote LED signals. Do not use J2 and J6 for these five functions if the host uses the ones included in the 80 pin connector.

<b>J2 Jumper Installation</b>		<b>Jumper Function Description</b>
<b>RES</b>		
<u>Off</u> /On		Reserved. Default is no jumper installed.
<b>DS</b>	<b>ME</b>	
<u>Off</u>	<u>Off</u>	Spindle starts immediately after power up - Default setting.
Off	On	Drive spindle does not start until Start Unit command received from host.
On	Off	Spindle Startup is delayed by SCSI ID times 12 seconds after power is applied, i.e., drive 0 spindle starts immediately when DC power connected, drive 1 starts after 12 second delay, drive 2 starts after 24 second delay, etc.
On	On	Drive spindle starts when Start Unit command received from host. Delayed start feature is overridden and does not apply when <b>ME</b> jumper is installed.
<b>WP</b>		
On		Entire drive is write protected.
<u>Off</u>		Drive is not write protected. Default is no <b>WP</b> jumper installed.
<b>PE</b>		
<u>On</u>		Parity checking and parity error reporting by the drive is enabled. Default is <b>PE</b> jumper installed.
Off		Drive does not report result of parity checking to host.

**J2 Jumper****Installation****Jumper Function Description****TE**On

With the jumper installed, the On-board (non-removable) terminator circuits are enabled (connected to the I/O lines). Default is jumper installed only on "N" models and "NC" models having factory installed terminator module U5.

Off

Terminator circuits not connected to I/O lines.

**TP****TP**

Off

Off

No terminator power is connected to drive terminators or SCSI bus I/O pin 26.

On

Off

Drive supplies its own terminator power only. Jumper on this position is factory **default** only for "N" models and "NC" models that have terminator module U5 (factory installed only).

Off

On

Jumper in this position is **default** for "ND" drives. Drive supplies power only to I/O pin 26 of SCSI bus. When drives have differential I/O circuits, a jumper on the right **TP** position may be needed to power external terminators (see system documentation). The ND model drives have differential I/O circuits which have no terminator circuits on the drive.

On

On

Drive supplies terminator power to itself (internal connection) and to I/O pin 26 of SCSI bus. This is a legal jumper setting.

**TP Position A**

- On This horizontally positioned jumper across the two **TP** positions nearest PCB edge, connects terminator power from SCSI bus I/O pin 26 to the drive's internal terminators (for single-ended I/O only).
- Off See above explanations for **TP** jumpers.

**J5 Jumper****Installation Jumper Function Description**

- 1,2,3 Drive ID on SCSI Bus (J6 may be used instead).
- (A<sub>0</sub>,A<sub>1</sub>,A<sub>2</sub>) The drive ID is binary coded positionwise i.e., jumper in position A<sub>2</sub> is drive ID 4, in position A<sub>1</sub> is ID 2, position A<sub>0</sub> is ID 1 and no jumpers is ID 0, Default is ID = 0. "NC" drives do not have J5.



**J6 Jumper****Installation****1,2,3****(A<sub>2</sub>,A<sub>1</sub>,A<sub>0</sub>)****Jumper Function Description**

Drive ID on SCSI bus. Either J5 or J6 (optional) may be used to select drive ID. Both should not be used at the same time, because at some future time when the ID is changed the user could fail to configure both J5 and J6 the same. (See note [2]).

**SSP**

A jumper is installed when not used as a cable connection for the reference index signal (REFIND+) (J6 Pin 6, bottom) for sync spindle feature. J6 pin 5 is GRD.

**LED**

No jumper ever installed. These pins used to connect a cable for a remote LED indicator. Pin 3 (top, nearest HDA), the anode connection, connects in the drive to the +5V supply through a pull-up resistor. Pin 4 (bottom), the cathode connection connects in the drive to signal common through the emitter-collector junction of a transistor switch that controls the LED on/off condition.

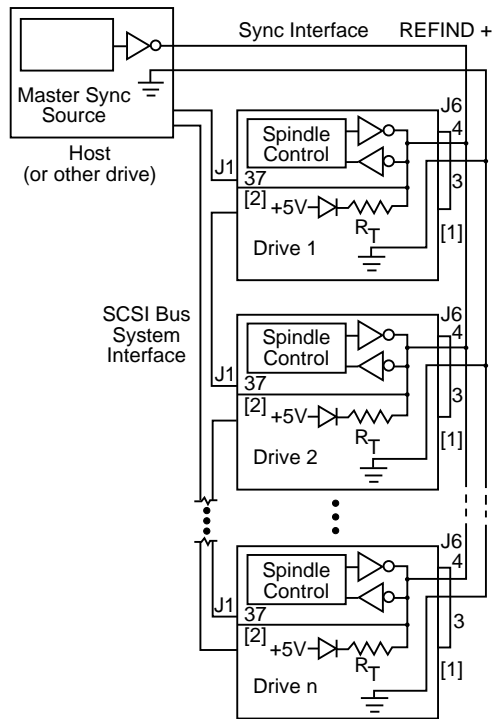

- [1] Configuration select header. See Figure 2.
- [2] Applies to "NC" models only.

**Figure 3. Synchronized spindle interconnection diagram for Hawk 2 family**

---

## **Drive installation**

This section describes the physical mounting of the drive in the host cabinet and the logical installation as a system member, which is called drive setup.

### **Disc drive mounting**

Do not touch the connector pins or any PCB components without observing static-discharge precautions. Always handle the drive by the frame only.

The drive may be mounted in any orientation. Drive models with the "NC" suffix may plug directly into a permanently mounted connector, in which case there is only one orientation that is correct. Note the shape of both Drive and host system connectors and orient drive to allow it to properly plug in.

- Mount to host system chassis using four 6-32 UNC screws. Three mounting holes are in each side and four in the bottom of the drive. See Figure 4. The maximum length that the screws should extend into the side chassis mounting holes is 0.150 inch (3.81 mm), and 0.20 inch (5.08 mm) into bottom holes, measured from the outer surface of the chassis. The minimum thread engagement for all mounting screws is .12 inch (3.0 mm). Tighten the screws evenly to a maximum torque of 8 in-lb. Do not over tighten or force when screw does not seem to screw in easily (threads not correctly engaged).
- Verify that all connections between the drive and the host system are correctly installed. Most cables have a contrasting color stripe indicating pin 1. Pin 1 on the drive I/O connector and the DC power connector are indicated in Figure 1. The "NC" drive 80 pin I/O connector is keyed by virtue of its shape.
- Verify option select and drive ID select jumpers and installation of terminator resistor packs where applicable. See Sections 2 and 3.

Do not power up the host system until the drive is mounted and the system cover is replaced.

- Connect DC power connector to the drive, except on "NC" model drives which do not have a separate DC power connector.
- Replace the Host System cover.
- Turn on DC power.
- Boot the system from the floppy drive or from a previously installed hard-drive if there is one.
- Proceed with drive setup of the new hard drive.

### **Grounding**

Signal ground (PCB) and HDA ground are connected together in the Hawk 2 family of drives and cannot be separated by the user. The equipment in which the drive is mounted is connected directly to the HDA and PCB with no electrically isolating shock mounts. If it is desired for the system chassis to not be connected to the HDA/PCB ground, the systems integrator or user must provide a nonconductive (electrically isolating) method of mounting the drive in the host equipment.

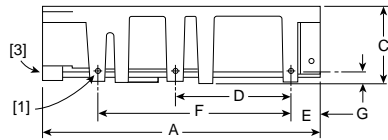

**Notes:**

- [1] Mounting holes three on each side, 6-32 UNC. Max screw length into side of drive 0.15 in. (3.81 mm). See "Disc Drive Mounting" paragraph.
- [2] Mounting holes four on bottom, 6-32 UNC. Max screw length into bottom of drive 0.20 in. (5.08 mm). See "Disc Drive Mounting" paragraph.
- [3] Power and interface connections may extend past the "A" dimension by 0.040 in. (1.02 mm).
- [4] On "NC" model drives the I/O and DC power are combined in a single 80 pin connector (not shown), which is centered within  $\pm 0.20$  in. (.51 mm) side to side on the PCB.

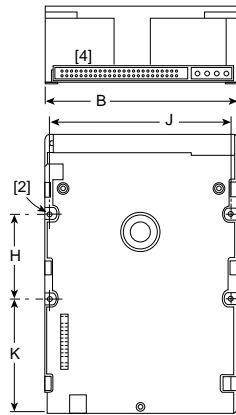

	Inches	Millimeters
A	5.74	145.80
B	4.00	101.60
C	1.62	41.15
D	2.362	60.00
E	.620	15.75
F	4.000	101.60
G	.250	6.35
H	1.750	44.45
J	3.750	95.25
K	2.370	60.20

**Figure 4. Hawk 2 family drive mounting dimensions**

---

## Drive setup

### SCSI interface drives

The SCSI interface handles both drive geometry and defect management internally or the "no drive installed" option can be selected for systems with SCSI drives.

All SCSI interface drives are low-level formatted at the factory. If you wish to low-level format the drive to optimize its performance for your system, consult the controller documentation for information on low-level formatting. Partitioning and high-level formatting can be done through DOS by way of the FDISK utility for partitioning, and FORMAT for high-level formatting. Consult your DOS manual for FORMAT and FDISK command options.

**Warning.** If an installed drive is low-level formatted, all user data stored on the drive is lost.

**Seagate Technology assumes no liability for lost user data.**



**Seagate Technology, Inc.**

**920 Disc Drive**

**Scotts Valley, CA 95066-4544, USA**

*Publication Number: 77767451, Rev. C*

*Printed in USA*